

A10s Plus-N

Receiving Card



Specifications

Change History

Document Version	Release Date	Description
V1.1.3	2023-12-30	Updated feature descriptions.
V1.1.2	2023-07-28	Update the low latency description.
V1.1.1	2022-12-27	<ul style="list-style-type: none"> • Updated the description of the maximum resolution. • Updated the low latency description. • Updated the dimensions diagram. • Updated the packing information. • Deleted the LVDS transmission.
V1.1.0	2022-11-01	Updated the appearance diagram.

Introduction

The A10s Plus-N is a high-end full-featured small receiving card developed by Xi'an NovaStar Tech Co., Ltd. (hereinafter referred to as NovaStar). For PWM driver ICs, a single A10s Plus-N supports resolutions up to 512x512@60Hz.

Supporting the exclusive Image Booster technology of NovaStar, the A10s Plus-N can precisely calibrate the color gamut and grayscale of the screen, and improve the grayscale by 64 times. It also supports the pixel level brightness and chroma calibration, quick seam correction, low latency, 3D, image rotation in 90° increments, individual gamma adjustment for RGB, free image rotation, HDR, and other functions, significantly improving the brightness, grayscale and color performance from every aspect and offering users an ultimate visual experience with a uniform, smooth and lifelike image.

The A10s Plus-N uses high-density connectors for communication to limit the effects of dust and vibration, resulting in high stability. It supports up to 32 groups of parallel RGB data or 64 groups of serial data (expandable to 128 groups of serial data). Its reserved pins allow for custom functions of users. Thanks to its EMC Class B compliant hardware design, the A10s Plus-N has improved electromagnetic compatibility and is suitable for various on-site setups that have high requirements.

Certifications

RoHS, EMC Class B

If the product does not have the relevant certifications required by the countries or regions where it is to be sold, please contact NovaStar to confirm or address the problem. Otherwise, the customer shall be responsible for the legal risks caused or NovaStar has the right to claim compensation.

Features

Improvements to Display Effect

- Image Booster (Effects depend on the driver IC)
 - Color Management: Support the standard color gamuts (Rec.709, DCI-P3 and Rec.2020) and custom color gamuts, enabling more precise colors on the screen.
 - Precise Grayscale: Individually correct the 65,536 levels of grayscale (16bit) of the driver IC to fix the display problems at low grayscale conditions, such as brightness spikes, brightness dips, color cast and mottling. This function can also better assist other display technologies, such as 22bit+ and individual gamma adjustment for RGB, allowing for a smoother and uniform image.
 - 22bit+: Improve the LED display grayscale by 64 times to avoid grayscale loss due to low brightness and allow for more details in dark areas and a smoother image.
- Pixel level brightness and chroma calibration
Work with NovaStar's high-precision calibration system to calibrate the brightness and chroma of each pixel, effectively removing brightness differences and chroma differences, and enabling high brightness consistency and chroma consistency.
- Quick adjustment of dark or bright lines
The dark or bright lines caused by splicing of cabinets or modules can be adjusted to improve the visual experience. This function is easy to use and the adjustment takes effect immediately.
- Low latency
For PWM driver ICs, the latency of video source on the receiving card end can be reduced to 1 frame.
- 3D
Working with the LED controller that supports 3D function, the receiving card supports 3D image output.
- Image rotation in 90° increments
The display image can be set to rotate in multiples of 90° (0°/ 90°/180°/270°).
- Individual gamma adjustment for RGB
Working with NovaLCT (V5.2.0 or later) and the LED controller that supports this function, the receiving card supports individual adjustment of red gamma, green gamma and blue gamma, which can effectively control image non-uniformity at low grayscale conditions and white balance offset, allowing for a more realistic image.
- Image rotation at any angle
Working with SmartLCT and the MCTRL R5 LED controller, the receiving card supports image rotation at any angle.
- HDR
 - Support HDR10 and comply with the SMPTE ST 2084 and SMPTE ST 2086 standards.
 - Support HLG.

Improvements to Maintainability

- Smart module (dedicated firmware required)
Working with the smart module, the receiving card supports module ID management, storage of calibration coefficients and module parameters, monitoring of module temperature, voltage and flat cable communication status, LED error detection, and recording of the module run time.
- Automatic module calibration
After a new module with flash memory is installed to replace the old one, the calibration coefficients stored in the flash memory can be automatically uploaded to the receiving card when it is powered on, ensuring high consistency for both display brightness and chroma.

- Quick uploading of calibration coefficients
The calibration coefficients can be quickly uploaded to the receiving card, improving efficiency greatly.
- Module Flash management
For modules with flash memory, the information stored in the memory can be managed. The calibration coefficients and module ID can be stored and read back.
- One click to apply calibration coefficients in module Flash
For modules with flash memory, when the Ethernet cable is disconnected, users can hold down the self-test button on the cabinet to upload the calibration coefficients in the flash memory of the module to the receiving card.
- Mapping 1.0
The cabinets display the receiving card number and Ethernet port information, allowing users to easily obtain the locations and connection topology of receiving cards.
- Setting of a pre-stored image in receiving card
The image displayed during startup, or displayed when the Ethernet cable is disconnected or there is no video signal can be customized.
- Temperature and voltage monitoring
The temperature and voltage of the receiving card can be monitored without using peripherals.
- Cabinet LCD
The LCD module connected to the cabinet can display the temperature, voltage, single run time and total run time of the receiving card.
- Bit error detection
The Ethernet port communication quality of the receiving card can be monitored and the number of erroneous packets can be recorded to help troubleshoot network communication problems.
- Status detection of dual power supplies
When two power supplies are used, their working status can be detected by the receiving card.
- Firmware program readback
The firmware program of the receiving card can be read back and saved to the local computer.
- Configuration parameter readback
The configuration parameters of the receiving card can be read back and saved to the local computer.

Improvements to Reliability

- Dual card backup and status monitoring
In an application with requirements for high reliability, two receiving cards can be mounted onto a single hub board for backup. When the primary receiving card fails, the backup card can serve immediately to ensure uninterrupted operation of the display.

The working status of the primary and backup receiving cards can be monitored in NovaLCT V5.2.0 or later.
- Loop backup
The receiving cards and the LED controller form a loop via the primary and backup line connections. When a fault occurs at a location of the lines, the screen can still display the image normally.
- Dual backup of configuration parameters
The receiving card configuration parameters are stored in the application area and factory area of the receiving card at the same time. Users usually use the configuration parameters in the application area. If necessary, users can restore the configuration parameters in the factory area to the application area.
- Dual program backup
Two copies of firmware program are stored in the receiving card at the factory to avoid the problem that the receiving card may get stuck abnormally during program update.
- Dual backup of calibration coefficients
The brightness and chroma calibration coefficients are stored in the application area and factory area of the receiving card at the same time. Users usually use the calibration coefficients in the application area. If necessary, users can restore the calibration coefficients in the factory area to the application area.

Appearance

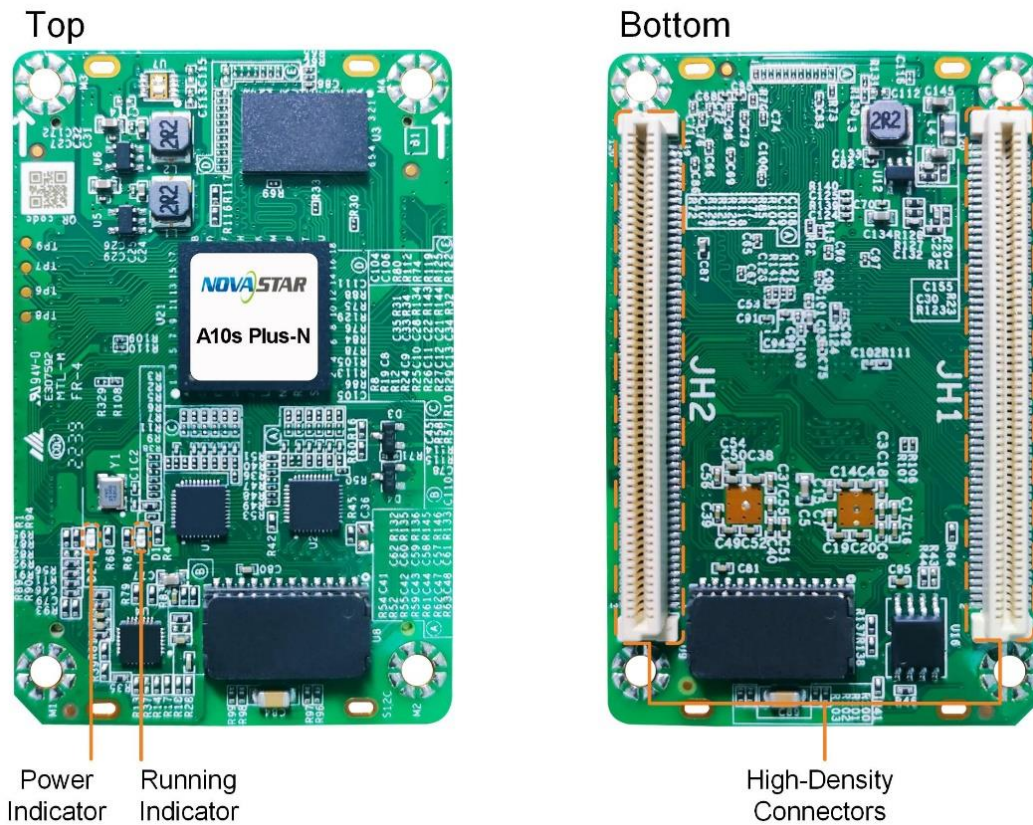

All product pictures shown in this document are for illustration purpose only. Actual product may vary.

Indicators

Indicator	Color	Status	Description
Running indicator	Green	Flashing once every 1s	The receiving card is functioning normally. Ethernet cable connection is normal, and video source input is available.
		Flashing once every 3s	Ethernet cable connection is abnormal.
		Flashing 3 times every 0.5s	Ethernet cable connection is normal, but no video source input is available.
		Flashing once every 0.2s	The receiving card failed to load the program in the application area and is now using the backup program.
		Flashing 8 times every 0.5s	A redundancy switchover occurred on the Ethernet port and the loop backup has taken effect.
Power indicator	Red	Always on	The power input is normal.

Dimensions

The board thickness is not greater than 2.0 mm, and the total thickness (board thickness + thickness of components on the top and bottom sides) is not greater than 8.6 mm. Ground connection (GND) is enabled for mounting holes.

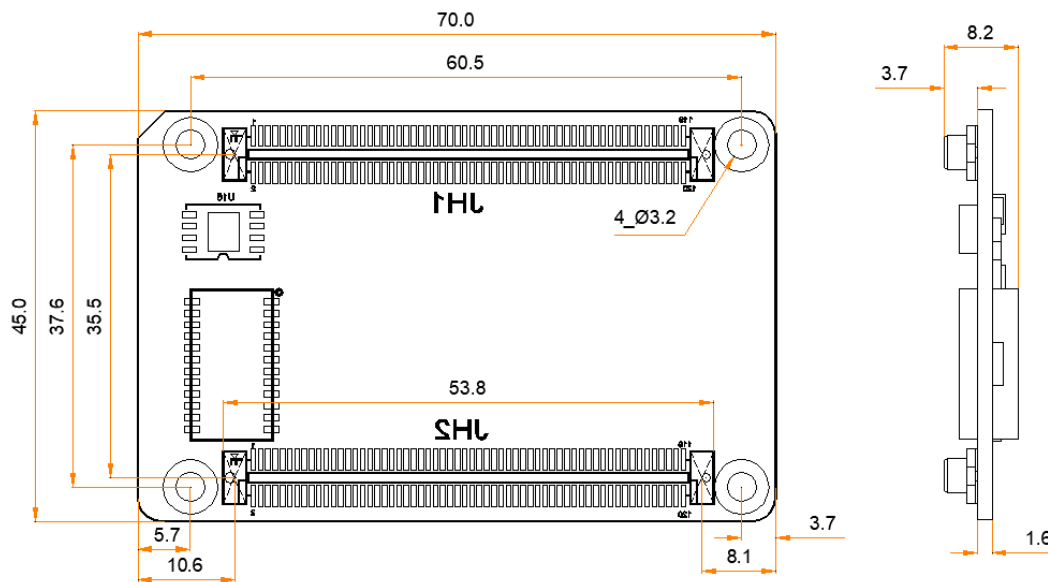

Tolerance: ± 0.3 Unit: mm

Note

The distance between outer surfaces of the A10s Plus-N and hub boards after their high-density connectors fit together is 5.0 mm. A 5-mm copper pillar is recommended.

To make molds or trepan mounting holes, please contact NovaStar for a higher-precision structural drawing.

Pins

[32 Groups of Parallel RGB Data](#)

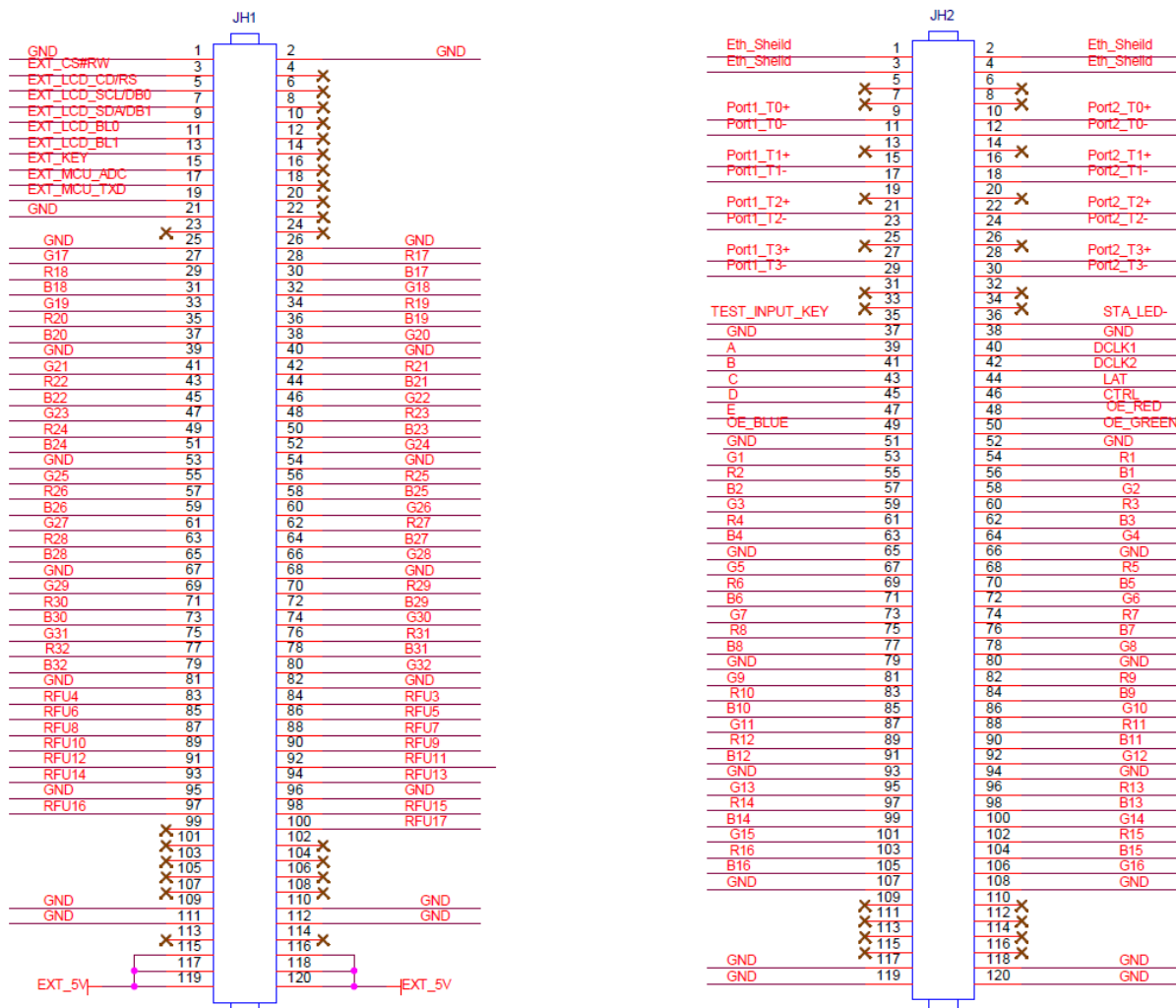

JH1					
	GND	1	2	GND	
LCD CS signal	EXT_CS#RW	3	4	NC	
LCD RS signal	EXT_LCD_CD/RS	5	6	NC	
LCD clock signal	EXT_LCD_SCL/DB0	7	8	NC	
LCD data signal	EXT_LCD_SDA/DB1	9	10	NC	
LCD backlight signal 1	EXT_LCD_BL0	11	12	NC	
LCD backlight signal 2	EXT_LCD_BL1	13	14	NC	
LCD control button	EXT_KEY	15	16	NC	
A reserved pin for MCU connection	EXT_MCU_ADC	17	18	NC	
A reserved pin for MCU connection	EXT_MCU_TXD	19	20	NC	
	GND	21	22	NC	
	NC	23	24	NC	
	GND	25	26	GND	
/	G17	27	28	R17	/
/	R18	29	30	B17	/
/	B18	31	32	G18	/
/	G19	33	34	R19	/
/	R20	35	36	B19	/
/	B20	37	38	G20	/
	GND	39	40	GND	
/	G21	41	42	R21	/
/	R22	43	44	B21	/
/	B22	45	46	G22	/

JH1					
/	G23	47	48	R23	/
/	R24	49	50	B23	/
/	B24	51	52	G24	/
	GND	53	54	GND	
/	G25	55	56	R25	/
/	R26	57	58	B25	/
/	B26	59	60	G26	/
/	G27	61	62	R27	/
/	R28	63	64	B27	/
/	B28	65	66	G28	/
	GND	67	68	GND	
/	G29	69	70	R29	/
/	R30	71	72	B29	/
/	B30	73	74	G30	/
/	G31	75	76	R31	/
/	R32	77	78	B31	/
/	B32	79	80	G32	/
	GND	81	82	GND	
/	RFU4	83	84	RFU3	/
/	RFU6	85	86	RFU5	/
/	RFU8	87	88	RFU7	/
/	RFU10	89	90	RFU9	/
/	RFU12	91	92	RFU11	/
/	RFU14	93	94	RFU13	/
	GND	95	96	GND	
/	RFU16	97	98	RFU15	/
	NC	99	100	RFU17	/
	NC	101	102	NC	
	NC	103	104	NC	
	NC	105	106	NC	
	NC	107	108	NC	
	GND	109	110	GND	
	GND	111	112	GND	
	NC	113	114	NC	
	EXT_5V	115	116	EXT_5V	
	EXT_5V	117	118	EXT_5V	
	EXT_5V	119	120	EXT_5V	

JH2					
Chassis ground	Eth_Sheild	1	2	Eth_Sheild	Chassis ground
Chassis ground	Eth_Sheild	3	4	Eth_Sheild	Chassis ground
	NC	5	6	NC	
	NC	7	8	NC	
Gigabit Ethernet port	Port1_T0+	9	10	Port2_T0+	Gigabit Ethernet port
	Port1_T0-	11	12	Port2_T0-	
	NC	13	14	NC	
	Port1_T1+	15	16	Port2_T1+	
	Port1_T1-	17	18	Port2_T1-	
	NC	19	20	NC	
	Port1_T2+	21	22	Port2_T2+	
	Port1_T2-	23	24	Port2_T2-	
	NC	25	26	NC	
	Port1_T3+	27	28	Port2_T3+	

JH2					
	Port1_T3-	29	30	Port2_T3-	
	NC	31	32	NC	
	NC	33	34	NC	
Test button	TEST_INPUT_KEY	35	36	STA_LED-	Running indicator (active low)
	GND	37	38	GND	
Line decoding signal	A	39	40	DCLK1	Shift clock output 1
Line decoding signal	B	41	42	DCLK2	Shift clock output 2
Line decoding signal	C	43	44	LAT	Latch signal output
Line decoding signal	D	45	46	CTRL	Afterglow control signal
Line decoding signal	E	47	48	OE_RED	Display enable signal
Display enable signal	OE_BLUE	49	50	OE_GREEN	Display enable signal
	GND	51	52	GND	
/	G1	53	54	R1	/
/	R2	55	56	B1	/
/	B2	57	58	G2	/
/	G3	59	60	R3	/
/	R4	61	62	B3	/
/	B4	63	64	G4	/
	GND	65	66	GND	
/	G5	67	68	R5	/
/	R6	69	70	B5	/
/	B6	71	72	G6	/
/	G7	73	74	R7	/
/	R8	75	76	B7	/
/	B8	77	78	G8	/
	GND	79	80	GND	
/	G9	81	82	R9	/
/	R10	83	84	B9	/
/	B10	85	86	G10	/
/	G11	87	88	R11	/
/	R12	89	90	B11	/
/	B12	91	92	G12	/
	GND	93	94	GND	
/	G13	95	96	R13	/
/	R14	97	98	B13	/
/	B14	99	100	G14	/
/	G15	101	102	R15	/
/	R16	103	104	B15	/
/	B16	105	106	G16	/
	GND	107	108	GND	
	NC	109	110	NC	
	NC	111	112	NC	
	NC	113	114	NC	
	NC	115	116	NC	
	GND	117	118	GND	
	GND	119	120	GND	

64 Groups of Serial Data

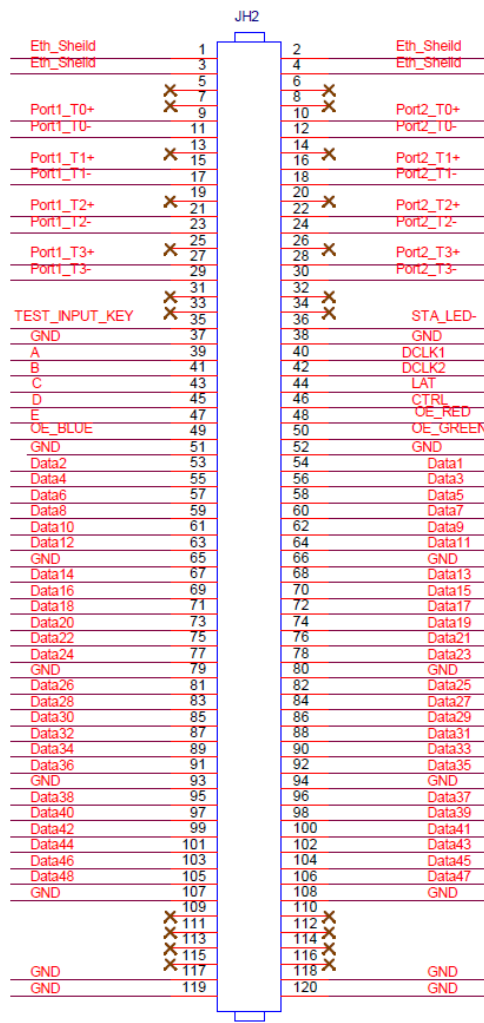
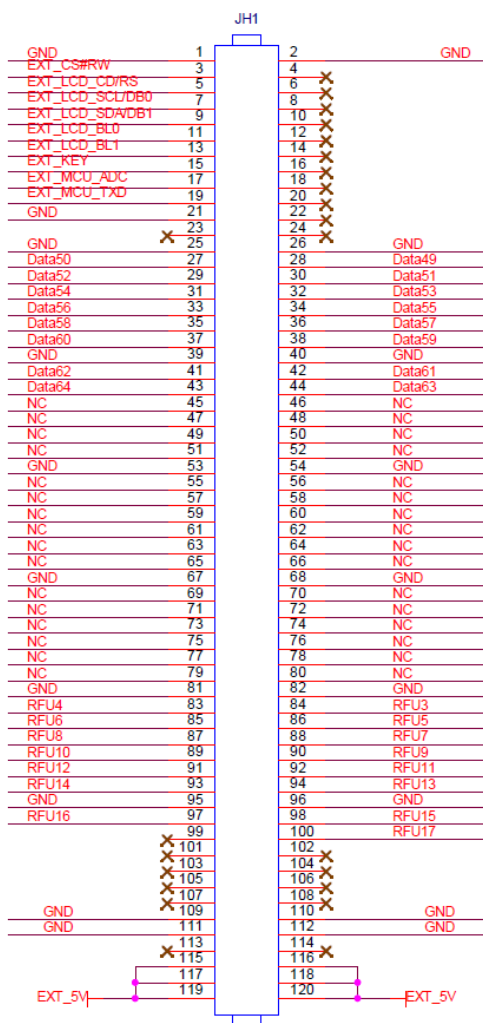

JH1					
	GND	1	2	GND	
LCD CS signal	EXT_CS#RW	3	4	NC	
LCD RS signal	EXT_LCD_CD/RS	5	6	NC	
LCD clock signal	EXT_LCD_SCL/DB0	7	8	NC	
LCD data signal	EXT_LCD_SDA/DB1	9	10	NC	
LCD backlight signal 1	EXT_LCD_BL0	11	12	NC	
LCD backlight signal 2	EXT_LCD_BL1	13	14	NC	
LCD control button	EXT_KEY	15	16	NC	
A reserved pin for MCU connection	EXT_MCU_ADC	17	18	NC	
A reserved pin for MCU connection	EXT_MCU_TXD	19	20	NC	
	GND	21	22	NC	
	NC	23	24	NC	
	GND	25	26	GND	
/	Data50	27	28	Data49	/
/	Data52	29	30	Data51	/
/	Data54	31	32	Data53	/
/	Data56	33	34	Data55	/
/	Data58	35	36	Data57	/
/	Data60	37	38	Data59	/
	GND	39	40	GND	
/	Data62	41	42	Data61	/
/	Data64	43	44	Data63	/
	NC	45	46	NC	

JH1					
	NC	47	48	NC	
	NC	49	50	NC	
	NC	51	52	NC	
	GND	53	54	GND	
	NC	55	56	NC	
	NC	57	58	NC	
	NC	59	60	NC	
	NC	61	62	NC	
	NC	63	64	NC	
	NC	65	66	NC	
	GND	67	68	GND	
	NC	69	70	NC	
	NC	71	72	NC	
	NC	73	74	NC	
	NC	75	76	NC	
	NC	77	78	NC	
	NC	79	80	NC	
	GND	81	82	GND	
/	RFU4	83	84	RFU3	/
/	RFU6	85	86	RFU5	/
/	RFU8	87	88	RFU7	/
/	RFU10	89	90	RFU9	/
/	RFU12	91	92	RFU11	/
/	RFU14	93	94	RFU13	/
	GND	95	96	GND	
/	RFU16	97	98	RFU15	/
	NC	99	100	RFU17	/
	NC	101	102	NC	
	NC	103	104	NC	
	NC	105	106	NC	
	NC	107	108	NC	
	GND	109	110	GND	
	GND	111	112	GND	
	NC	113	114	NC	
	EXT_5V	115	116	EXT_5V	
	EXT_5V	117	118	EXT_5V	
	EXT_5V	119	120	EXT_5V	

JH2					
Chassis ground	Eth_Sheild	1	2	Eth_Sheild	Chassis ground
Chassis ground	Eth_Sheild	3	4	Eth_Sheild	Chassis ground
	NC	5	6	NC	
	NC	7	8	NC	
Gigabit Ethernet port	Port1_T0+	9	10	Port2_T0+	Gigabit Ethernet port
	Port1_T0-	11	12	Port2_T0-	
	NC	13	14	NC	
	Port1_T1+	15	16	Port2_T1+	
	Port1_T1-	17	18	Port2_T1-	
	NC	19	20	NC	
	Port1_T2+	21	22	Port2_T2+	
	Port1_T2-	23	24	Port2_T2-	
	NC	25	26	NC	
	Port1_T3+	27	28	Port2_T3+	
Port1_T3-	29	30	Port2_T3-		
	NC	31	32	NC	
	NC	33	34	NC	

JH2					
Test button	TEST_INPUT_KEY	35	36	STA_LED-	Running indicator (active low)
	GND	37	38	GND	
Line decoding signal	A	39	40	DCLK1	Shift clock output 1
Line decoding signal	B	41	42	DCLK2	Shift clock output 2
Line decoding signal	C	43	44	LAT	Latch signal output
Line decoding signal	D	45	46	CTRL	Afterglow control signal
Line decoding signal	E	47	48	OE_RED	Display enable signal
Display enable signal	OE_BLUE	49	50	OE_GREEN	Display enable signal
	GND	51	52	GND	
/	Data2	53	54	Data1	/
/	Data4	55	56	Data3	/
/	Data6	57	58	Data5	/
/	Data8	59	60	Data7	/
/	Data10	61	62	Data9	/
/	Data12	63	64	Data11	/
	GND	65	66	GND	
/	Data14	67	68	Data13	/
/	Data16	69	70	Data15	/
/	Data18	71	72	Data17	/
/	Data20	73	74	Data19	/
/	Data22	75	76	Data21	/
/	Data24	77	78	Data23	/
	GND	79	80	GND	
/	Data26	81	82	Data25	/
/	Data28	83	84	Data27	/
/	Data30	85	86	Data29	/
/	Data32	87	88	Data31	/
/	Data34	89	90	Data33	/
/	Data36	91	92	Data35	/
	GND	93	94	GND	
/	Data38	95	96	Data37	/
/	Data40	97	98	Data39	/
/	Data42	99	100	Data41	/
/	Data44	101	102	Data43	/
/	Data46	103	104	Data45	/
/	Data48	105	106	Data47	/
	GND	107	108	GND	
	NC	109	110	NC	
	NC	111	112	NC	
	NC	113	114	NC	
	NC	115	116	NC	
	GND	117	118	GND	
	GND	119	120	GND	

Note

The recommended power input is 5.0 V.

OE_RED, OE_GREEN and OE_BLUE are display enable signals. When RGB are not controlled separately, use OE_RED. When the PWM chip is used, they are used as GCLK signals.

In the mode of 128 groups of serial data, Data65–Data128 are multiplexed into Data1–Data64.

Reference Design for Extended Functions

Pins for Extended Functions			
Pin	Recommended Smart Module Pin	Recommended Module Flash Pin	Description
RFU4	HUB_SPI_CLK	Reserved	Clock signal of serial pin
RFU6	HUB_SPI_CS	Reserved	CS signal of serial pin
RFU8	HUB_SPI_MOSI	/	Module Flash data storage input
	/	HUB_UART_TX	Smart module TX signal
RFU10	HUB_SPI_MISO	/	Module Flash data storage output
	/	HUB_UART_RX	Smart module RX signal
RFU3	HUB_CODE0		Module Flash BUS control pin
RFU5	HUB_CODE1		

Pins for Extended Functions		
RFU7	HUB_CODE2	74HC164 data signal
RFU9	HUB_CODE3	
RFU11	HUB_H164_CSD	
RFU13	HUB_H164_CLK	Dual power supply detection signal
RFU14	POWER_STA1	
RFU16	POWER_STA2	Dual card backup connection signal
RFU15	MS_DATA	
RFU17	MS_ID	Dual card backup identifier signal

Note

The RFU8 and RFU10 are signal multiplex extension pins. Only one pin from either the Recommended Smart Module Pin or the Recommended Module Flash Pin can be selected at the same time.

Specifications

Maximum Resolution	512x512@60Hz (PWM driver ICs)	
Electrical Parameters	Input voltage	DC 3.8 V to 5.5 V
	Rated current	0.6 A
	Rated power consumption	3.0 W
Operating Environment	Temperature	-20°C to +70°C
	Humidity	10% RH to 90% RH, non-condensing
Storage Environment	Temperature	-25°C to +125°C
	Humidity	0% RH to 95% RH, non-condensing
Physical Specifications	Dimensions	70.0 mm × 45.0 mm × 8.2 mm
	Net weight	22.3 g Note: It is the weight of a single receiving card only.
Packing Information	Packing specifications	Each receiving card is packaged in a blister pack. Each packing box contains 80 receiving cards.
	Packing box dimensions	392.0 mm × 200.0 mm × 123.0 mm

The amount of current and power consumption may vary depending on various factors such as product settings, usage, and environment.